

Eneo Double Toilet Roll Holder with Shelf

EN15

Finish: Chrome

Custom Finishes available:

Specialty finishes available upon request.

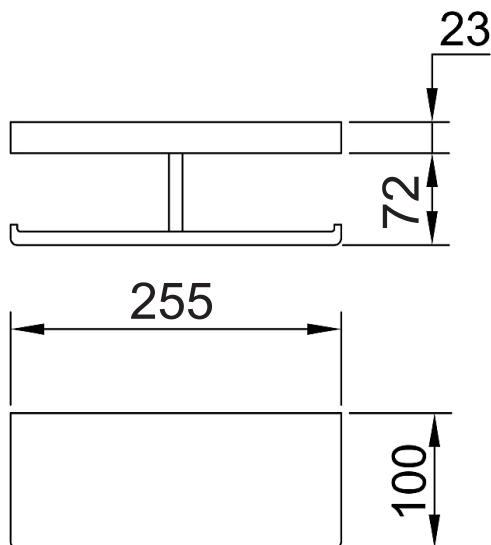

By combining the square geometric form with the gentleness of curved corners, the Eneo double toilet roll holder with shelf has perfectly captured today's design trend. That trend is contemporary luxury. Contemporary, through the use of straight lines. Luxury, through generous proportions, softened edges and chrome plated brass construction.



*Conditions apply.