



URBANE II COMPACT TWIN SHOWER

VISIT SPECIFY.CAROMA.COM.AU

The below products have been shared with you through the Caroma Specify website.

Visit specify.caroma.com.au to find more inspirational and innovative bathroom products.



URBANE II COMPACT TWIN SHOWER

Your shower is one of the most important features of your bathroom and the slim, sleek design of Urbane II Showers is perfect for an effortless modern design. Choosing the right type of shower for your bathroom from the Urbane II Showers Collection will ensure a luxurious showering experience every time.

*Premium quality flow regulators to deliver a consistent flow of water under a range of water pressures *V-Jet® technology delivers variable spray at your control, from a firm, invigorating spray to relaxing and everything in between *Easy slide rail height adjustment *Smooth, silverflex shower hose for durability and easy cleaning *WELS 4-Star rated, WELS 4 (Range E) rated, 7.5L/min *Caroma tapware is 100% leak tested *Available in Chrome, Matte Black, PVD Brushed Nickel, PVD Brushed Brass, PVD Gunmetal *20-year warranty *Match with complete Urbane II Bathroom Collection

PRODUCT CODES

99632C3A	Urbane II Compact Twin Shower - Chrome	\$599.00*
99632B3A	Urbane II Compact Twin Shower - Matte Black	\$659.00*
99632GM3A	Urbane II Compact Twin Shower - Gunmetal	\$775.00*
99632BB3A	Urbane II Compact Twin Shower - Brushed Brass	\$775.00*
99632BN3A	Urbane II Compact Twin Shower - Brushed Nickel	\$775.00*



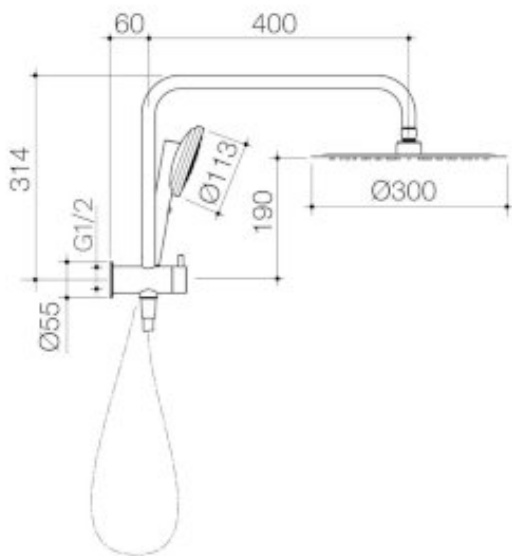

© COPYRIGHT 2014 - CAROMA INDUSTRIES LIMITED



*All price are recommended retail inclusive of GST in AUD. To be used as a guide only, prices may vary between model variations, and are subject to change without notice. A number of brands and products on this page are the subject of registered trade marks, register designs and/or registered patents. View full disclaimer on specify.caroma.com.au