

DIMENSIONS

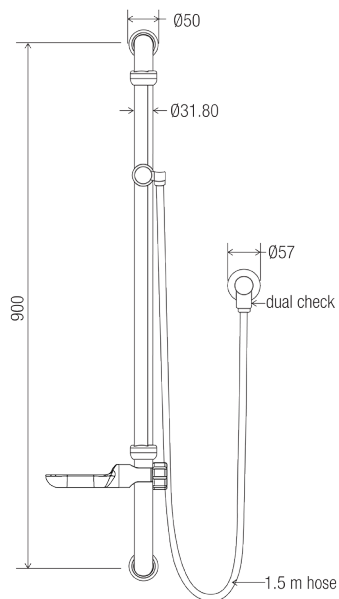

INDICATIVE IMAGE



STREAMJET™/PREMIUM HOSFAB®

Product Code - Finish

- GB 900J C - Chrome

Features

- Polish Supreme™ 900 mm HYGIENIC SEAL® grab rail
- Fabricated from 32 mm 304 stainless steel
- Mount grab rail 1900 mm above finished floor level
- Brass 700 mm friction slide track
- Brass handset cradle for handset support and height adjustment
- ABS 100 mm single function shower with rub-clean spray diffusor
- PVC 1500 mm Silverflex™ hose with ½" BSP swivel conical end nut
- DR brass wall outlet elbow with flow INTERCHANGE® spigot
- Brass 57 mm wall flange
- ABS grab rail soap dish
- Stainless steel fixings supplied
- Chrome plated finish
- Full pattern spray



Compliance

- Complies with clause 17 of AS 1428.1-2009 for design and construction of grab rails
- Complies with clause 15.5.4 of AS 1428.1-2009 for sanitary facilities
- Watermark AS/NZS 3662 WMKT 21147
- 3 Star - 9 L/min as per WELS licence number 0046
- 4 Star - 6.5 L/min as per WELS licence number 0046



Warranty

See Con-Serv warranty policy for full details.

CON-SERV CORPORATION AUSTRALIA PTY. LTD.

17 Glentanna Street, Kedron · Qld. 4031 Australia

Phone: +61 (0)7 3630 5744 · Fax: +61 (0)7 3630 5755 · Email: mail@con-serv.com.au · www.con-serv.com.au